

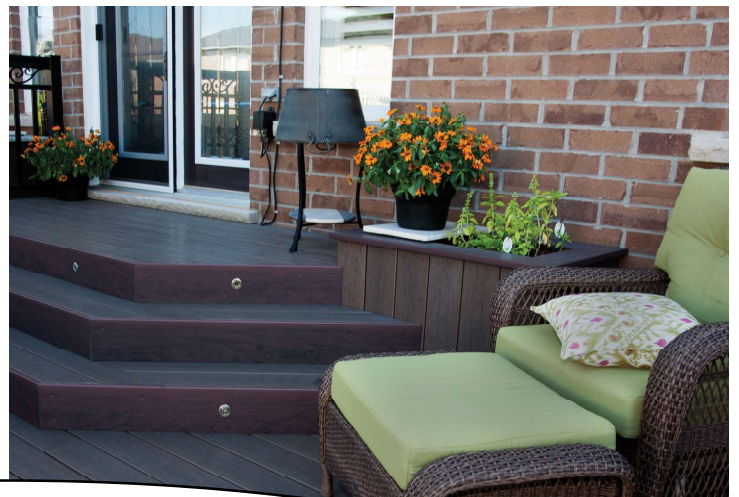

# CLUBHOUSE<sup>®</sup>

DECKING



## CLUBHOUSE DECKING INSTALLATION INSTRUCTIONS

# Clubhouse Decking Care and Maintenance

## General:

### Exceeding recommended concentration of cleaners can damage the products surface.

Follow manufacturers instructions for proper use of cleaning products. Avoid abrasive cleaners. Test any cleaner in an inconspicuous area before applying to major areas. Excessive scrubbing is unnecessary, may be harmful to the product and may cause an undesirable glossy area over the finish.

## Routine Cleaning/dirt and Grime:

As with all outdoor products, common dirt and dust should be cleaned occasionally with a garden hose or soft-bristled brush. Clubhouse Decking is low-maintenance, not no-maintenance products.

## Approved Cleaners:

Many household type cleaners may be used on Clubhouse Decking, however it is a good idea to test any intended cleaner on a small sample piece of material prior to using on the full installation. The following is a list of household cleaners that may be used:

- Dawn® (good for grease spots)
- Fantastic®
- Murphy Oil Soap®
- Lestoil®
- Windex®
- Lysol®
- Simple Green

## Hard Water Stains:

**Step 1:** Fill a spray bottle with 50% pure white vinegar and 50% water.

**Step 2:** Spray this vinegar solution onto the stain and let stand 5 minutes.

**Step 3:** Mix 4 cups water with 5 tablespoons of sodium bicarbonate (baking soda) and stir into a slurry.

**Step 4:** Soak a cleaning cloth/sponge in the sodium bicarbonate solution and thoroughly wipe the area of the stain that had the vinegar spray.

**Step 5:** Rinse well with water.

## Heavy Duty Cleaning

### (Industrial dirt/grease/oil/wine):

Substances such as grease, oil and wine require immediate attention. Rinse with hot water upon contact. For heavier dirt and stains, use a mixture containing 1 gallon of water, 1/3 cup of detergent such as Tide and 2/3 cup of trisodium phosphate (TSP, Soilax or similar product).

## Power Washing:

Although not required, Clubhouse Decking may be power washed with a gas or electric-powered spray hose. The level of the power washer should be set no higher than 1100 pounds per square inch (psi). A fan tip nozzle should be used along with the proper cleaning product. For decking, spray in the direction of the brush/grain pattern to avoid damaging the product. Use caution not to damage the material and always take the proper safety precautions when operating a power washer.

## Mold and Mildew:

Clubhouse products are formulated to inhibit mildew growth and minimize staining. Even if they appear clean, it is important to prevent build-up of pollen/debris. Mildew stains may occur where moisture, pollens and/or dirt are present. Mildew needs a food source to grow, which can be grass, pollens and dirt. Follow the routine cleaning directions to reduce build up on decking.

Mildew may appear as black spots and may be cleaned with a simple mixture of 1 gallon of water, 1/3 cup of detergent, 2/3 cup of Soilax (or like product) and 1 quart of household bleach. Although it may sit on the deck surface, mold and mildew will not penetrate and degrade the product, unlike wood.

## Cleaning Between Deck Planks:

Use a plastic putty knife and gently clean between decking planks to clear debris.

### **Barbeque grills, chimeneas and portable fire pits:**

All sources of high heat should be placed on a non-rubber/non-vinyl grill mat or splatter guard to minimize stains and kept a safe distance from railing. With any cleaning job that requires more than just water and a brush, we recommend that you try cleaning a small inconspicuous area or scrap piece of material before cleaning the entire surface.

### **Caulking, tar, compounds and similar substances:**

Clean with mineral spirits in reasonable amounts, applied directly to the substance. **AFTER CLEANING RINSE OFF IMMEDIATELY WITH SOAPY WATER.**

### **Rust:**

Use a deck cleaner containing phosphoric acid and commercial pressure washer (not to exceed 1100 PSI; see additional information under power washing)

### **Snow and Ice Removal:**

Snow may be removed from deck surface using a non-metallic shovel. Sharp shovels that scrape or chip wood deck should not be used. While salt/rock salt will not affect the structural integrity of Clubhouse, it may cause stains. If using salt to break up ice patches, remove salt as soon as possible to avoid stains and scratches. Do not use salt/ash mixtures. Ice melt product containing calcium chloride and/or magnesium chloride can be used on Clubhouse. It is a good idea to test any such products on a small sample piece prior to using on the full installation.

### **Splintering and Rotting:**

Clubhouse is guaranteed not to split, splinter or rot when installed according to manufacturers instructions.

### **Pools and Spas:**

Clubhouse Decking is designed to be used in conjunction with all outdoor living activities. Chlorinated water from pools and spas will not harm Clubhouse products.

### **Slip Resistance:**

Clubhouse Decking meets the Americans with Disabilities Act (ADA) Requirements.

### **Docks, Marine and Seaside Installations:**

Clubhouse Decking is designed to withstand marine/seaside environments. It's the perfect choice for docks, boat slips and beach house decks.

### **Rubber or Vinyl Mats:**

The use of rubber or vinyl products such as door mats and catch mats under barbeque grills or other rubber or vinyl products is not recommended as these products may cause discolouration of the deck.

### **Environmental Blushing:**

This is caused by build up of heat and moisture due to a wide surface area of deck being covered (e.g. by flower pots, rubber backed grill mats). Do not use rubber backed mats on Clubhouse Decking. Raise flower pots with stands/footers to allow airflow under the pot.

### **Low-E Glass:**

Reflection from Low-E glass and windows can cause excessive heat build up on decking. See website, [www.clubhousedecking.com](http://www.clubhousedecking.com) for further information.

Given the right environmental conditions all surfaces will get hot. When installing dark colours in hot sunny climates it is recommended that you test samples in the area prior to installation.

## **Clubhouse Decking Installation Instructions**

Updates to this installation guide are posted on the Clubhouse website. Please visit for additional information.

Clubhouse Decking features Korelite™ and Sunshield® technology with performance in mind. Clubhouse Decking should be installed using the



same building requirements used for wood or composite decking and should adhere to local building codes. Clubhouse Decking products meet and exceed the acceptable criteria for the Universal Building Code's CCRR Tested in Compliance with ICC-ES AC174 requirements. ASTM D 7032-08 and ICC-ES AC10. See website for CCRR report: CCRR-0175 (Clubhouse Decking).

**WARNING: Parts have sharp points and edges. Use extreme caution when handling and installing. Wear safety glasses and PPE at all times.**

#### **Storage and Handling:**

Although all Clubhouse PVC Deck planks are made with low maintenance materials, each plank should be handled with care to ensure lasting beauty.

- Keep product covered. Use shrouds on jobsite to protect from sun.
- Store under cover to maintain a clean surface.
- Store flat and on a dry surface.
- Stack units with banding and bottom supports aligned.
- Do not store more than 12 bundles high.
- Never dump Clubhouse PVC Deck planks when unloading.
- Always carry the plank on edge for better support.
- Do not slide planks against each other or drag equipment including tools across the top of the planks.
- When loading/unloading do not pick up more than 3 packs (12' and 16') or 2 packs (20') at one time.
- During construction keep the surface of planks clear of waste and debris.
- During storage product temperature should not exceed 120°F.

#### **Recommended Tools for Installation:**

Clubhouse PVC Deck planks require no special tools for installation. The following is a list of standard tools required:

- Variable speed drill
- 3/16" drill bit
- Plate joiner (for use with hidden fastener system)
- Circular saw with carbide-tipped blade (minimum 60 teeth)

- Jigsaw - A finer tooth blade will leave a cleaner cut. The blade should have 10 or more teeth per inch with a reverse setting on the teeth.
- Tape measure
- Framing square
- Pencil
- Safety glasses
- Rubber mallet
- Chalk line (clean off chalk with water)

***Because of the density of the Clubhouse PVC plank, nails and nail guns are not recommended.***

**Ventilation is required.** There must be unobstructed continuous airspace beneath the deck to allow for proper ventilation. A minimum of 6 inches of free air space is required under the deck planks, or one sq. ft. of ventilation for every 300 cubic feet of air space. This will allow for proper air flow and will reduce moisture build up produced by condensation and reduce heat build up on sunny days.

- The use of lattice panels are permitted as long as the lattice openings are, at minimum, as wide as the lattice slats.
- Clubhouse PVC deck planks should never be used for roof applications, directly on top of or attached to a cement slab or existing deck, or installed directly in contact with the ground.
- Use caution when installing decking where reflection from Low-E glass and windows could cause extreme heat build up. (See website [www.clubhousedecking.com](http://www.clubhousedecking.com) for further information).
- Use surface vents when using under deck and/or when ventilation of the deck is not available. A 2" x 48" fiberglass strip vent can be let into the decking boards for a flush look (these are removable for periodic cleaning).
- Side vents in joists can also be installed to help improve airflow.
- Add sleepers in potential affected areas at 8" on center.
- Use shade trees/awning to help reduce heat build up

***Failure to provide adequate ventilation may result in damage to the product and will void the warranty.***

### Joist Spacing for New and Existing Frames:

For both new and existing deck frames, use the following guidelines for joist spacing prior to installing Clubhouse PVC Decking.

**IMPORTANT:** Clubhouse PVC Decking is a load bearing material but should NEVER be used for structural framing. Consult your local building codes for specific information.

- For proper installation joist system must be level
- Residential installations: 5/4" plank up to 16" on center. For diagonal installations reduce span by 4". For optimum feel use 12" spacing.
- Commercial installations: Review local building codes for framing requirements.
- Stairs: 5/4" plank up to 10" on center.
- To aid in water run-off and reduced pooling, the deck should slope 1/2" for every 8' away from structure.

### Traditional Screw Down Installation:

We recommend surface screws designed for dense PVC Decking. Always refer to the fastener manufacturer's recommendations and warranties to determine the best one for the job.

Always choose fasteners that have an ACQ rated finish and one that is guaranteed by the fastener manufacturer. Fasteners must also comply with ASTM A153 or current code. For best results use Clubhouse Hidden Fastening Systems and Cortex plugs.

**Note:** Be sure to test screws on a scrap piece of Clubhouse PVC Decking prior to installation.

The use of nails and nail guns is not recommended with Clubhouse PVC Decking.

### Clubhouse Screw Colour Charts

Hardwoods				
Manufacturer	Ipe	Walnut	Mahogany	Ironwood
Dexter Swan	Tan	Kona	Jatoba	Gray
Split Stop Titan III	Hickory/ Cedar	Dk. Brown	Redwood/ Dk. Brown	Gray
Composi-lok Simpson Strong Tie	Tan	Redwood	Redwood	Gray
DeckFast Starborn	Cedar	Chocolate	Burgundy	Gray

Earthtones				
Manufacturer	Brookstone	Cobblestone	Sandstone	Clay
Dexter Swan	Lt. Gray	Mocha	Almond	Khaki
Split Stop Titan III	Gray	Cedar	Cedar	Cedar
Composi-lok Simpson Strong Tie	Gray	Tan	Tan	Tan
DeckFast Starborn	Gray	Sand	White	Sand

Recommended fastening systems for Clubhouse Decking are Clubhouse Connect Clips, Clubhouse Cortex® Hidden Fastening System, and Clubhouse Biscuit.

For colour match paint and caulk see Clubhouse website.

Other approved fastening systems include: HF Biscuit, HIDfast, TigerClaw TC-G, CAMO, The Deck Clip, DeckMaster, UnderDeck.

Here are some best practices:

- Pre-drilling is recommended for the best overall appearance with most fasteners
- Always start the screw at a slower speed and maintain a steady speed and pressure. This allows the screw to cut into the plank, rather than merely burn or spin.
- Mushrooming is a term that refers to the "bubble" of material that forms around the screw head as the threads exhaust PVC plank material toward the surface, resulting in a mushroom-like appearance.
- To avoid mushrooming, pre-drilling is recommended. Keep drill at a constant, steady speed until the fastener is completely flush or countersunk approx 1/16".
- Temperature, humidity and the moisture of the substructure can affect how much a PVC plank mushrooms.

## Guidelines for Bending Clubhouse Deck Planks

- Using dry heat source, heat planks slowly to 170°F for 1/2 hour.
- Build guide system to lay plank in. Place plank into guide system slowly. “Do not apply stress”.
- Once the plank is in the guide system allow to cool (the temperature of the plank should be below 90°F) before applying screws.
- The recommended minimum radius for 16' planks is 8'.

## Colour Patterns and Variation of Variegated Clubhouse Hardwood Decking

**Clubhouse Hardwood Decking is designed with vaiegation and variation in colour and patterns. For best results during installation it is recommended that multiple courses of planks be laid out prior to installation. The courses should be reviewed for desired effect. This process is most critical when installing boards from multiple bundles of material. Mixing colours and patterns will allow for the most realistic replication of true hardwood decking.**

Clubhouse deck planks should be installed in the same direction. To do this, identify the side with the date code and identification information on the side of the plank.

Install the planks consistently with this marking on the same side. This will allow for a more consistent appearance.

### Screw Down Installation Process:

- Begin installing planks at the outside edge of the deck and work back toward the structure. Screws should not be placed closer than 3/4" from end of edge of plank.
- Notch first plank to fit around any wood posts as necessary.
- Install the first plank with colour-coordinated screws using two screws per plank, per joist.

- To minimize the strain on screws and the deck board, use PL Premium Max on perimeter rim joists, particularly for boards running parallel on top of, and fastened to the rim joists.
- Continue installing planks across the joists, allowing a 1/8" gap between planks. Gapping allows for expansion of planks for proper water drainage. (See figure 2). Planks should be fastened at every joist, 16" on center.
- When butting planks end to end, planks should only butt together over a joist or other proper support. Use a double joist at butt ends. For the best appearance options, miter ends at 45 degrees or step overlap ends of the butt joint. (See figure 3.)
- Always consult your local building code for application procedures.
- Do not allow Clubhouse PVC planks to overhang more than 1-1/4" on all exposed sides of the deck.

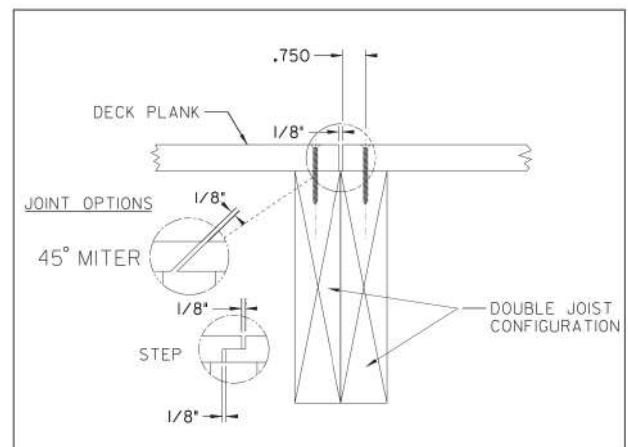

FIGURE 3

## Expansion and Contraction

All synthetic decking material will expand and contract as temperatures change. We recommend the following to help manage and minimize expansion and contraction:

**Expansion/Contraction chart (for free floating 16' boards)**

Temp Change °F	Expansion/Contraction of Plank	
	Inches	Nearest 16 <sup>th</sup> Inch
40	0.177	3/16
45	0.199	3/16
50	0.221	4/16
55	0.243	4/16
60	0.265	4/16
65	0.287	5/16
70	0.309	5/16
75	0.331	5/16
80	0.353	6/16

Ambient Temperature	End to End Minimum Gap	Side by Side Minimum Gap
Above 70° F	No gap	1/8"
32° - 70° F	1/8"	1/8"
Below 32° F	Installation is not recommended below 32° F	

- Try to cut and install boards during the average temperature range expected over the life of the deck. Installing during high heat or low temperatures requires very careful planning and may lead to undesired end to end spacing
- Use shrouds and keep deck boards covered during storage and at job site.
- Remember temperature of boards may be higher than ambient temperature, especially on hardwoods and boards left in direct sunlight.
- Use feature strips to create design features and reduce seams (see Figure 2b).
- Fasten with 2 screws/Cortex plugs 3/4" from end of each plank and allow expansion and contraction to move to the perimeter of the deck (see Figure 2a).

**See website for more information.**

● = Screw/Cortex Plug

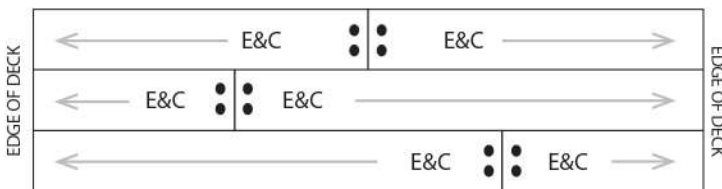

One Seam Application

FIGURE 2a

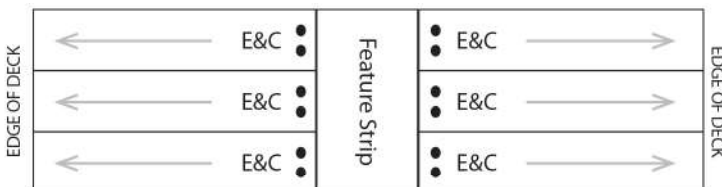

Use of Feature Strip

FIGURE 2b

**Fascia Installation**

**Due to the width of the fascia board, it is not uncommon that both sides will vary from each other in colour. Please choose a side that you feel represents the look of the deck and surrounding fascia boards.**

- Measure and cut fascia to length, allow for a 1/8" gap between fascia planks and butt joints. (See Figure 4.)
- Install fascia with matching colour screws (minimum length 1-1/2"). If using new, wet lumber pre-drill a hole that is slightly larger than the screw shaft to allow for contraction as the sub-structure dries.
- PL Premium Max (by LePage) construction adhesive is required when securing fascia to solid wood rim joists. The wood rim joists will expand and contract at different rates than the Clubhouse material and without adhesive, extreme temperatures could break the screws or boards. If using an alternative adhesive, you must check with the adhesive manufacturer to make sure their product may be used with Clubhouse PVC Decking and Fascia. Manufacturer assumes no responsibility for the use of adhesives outside of the recommended PL Premium Max product.
- Screws should be installed at a maximum of 16" intervals, 3/4" from edge and end of plank.
- 12" width fascia use 3 fasteners evenly spaced
- 5.5" fascia or deck plank use 2 fasteners evenly spaced
- Never allow fascia to extend more than 1-1/4" below an unsupported joist. On 12" fascia installations apply PL Premium Max directly to the rim of joist surface. See Figure 4 for screw pattern. Cortex plugs cannot be used for 12" fascia.

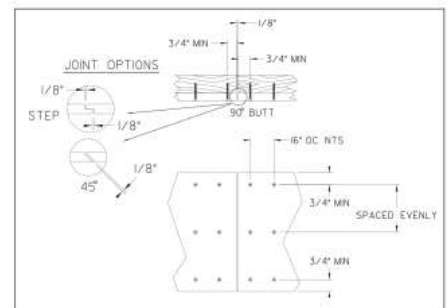
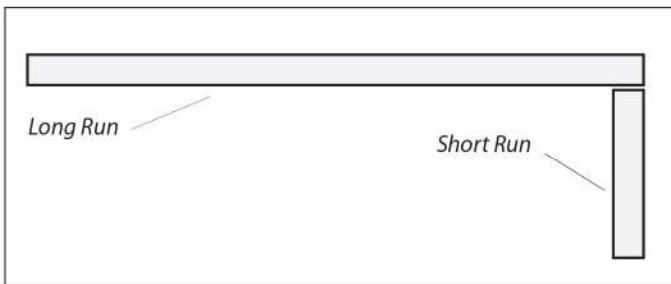

FIGURE 4

**Note: Fascia should be mounted on a clean, smooth surface for best results.**

Note: Miter joint is not recommended on fascia. Dead butt fascia with long run running past the short run (see diagram below).



### Hidden Fastener System Installation

Clubhouse PVC Hidden Fastener planks are designed to allow for easy installation - even by one person. No special tools are required to install the planks (see installation tools for a complete list). There are a number of hidden fasteners currently available today (including deck clips and biscuits) that have been used successfully to install Clubhouse decking.

There are 3 Clubhouse branded, private label systems: Clubhouse Connect Clips and Clubhouse Cortex (private label partnership with FastenMaster); and Clubhouse 'EB-TY' Biscuit (private label partnership with EB-TY). If using other systems you should always consult the manufacturer of the fastener to see if their product has been fully tested for use with Clubhouse Decking.

Manufacturer is not responsible for any failure that is a direct result of the hidden fastener.

## CLUBHOUSE FASTENING SYSTEMS

### Connect Clips Hidden Fasteners

#### GETTING STARTED / INSTALLATION DETAIL

**IMPORTANT:** Read all instructions carefully and completely to ensure proper installation.

**WARNING: Parts have sharp points and edges. Use extreme caution when handling and installing. Wear safety glasses and PPE at all times.**

#### Tools and materials needed:

- Safety glasses
- Rubber mallet
- Power screw gun with ratcheting torque setting

#### Step 1: Installing the first board

Fasten one edge of the first board at each framing support using Cortex Fasteners for Clubhouse Decking or another brand of quality 2-1/2" (63.5mm) deck screw.

It is important that this board is straight and well secured. Allow minimum of 1/4" (6.35mm) gap between house and first deck board. Follow fastener guidelines.

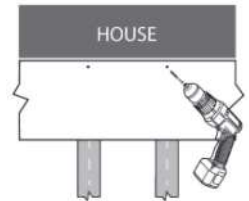

#### Step 2: Position Fasteners

Fully insert Clubhouse Connect Clip fastener into grooved edge of deck board. Screw hole should line up with the center of the support joist.

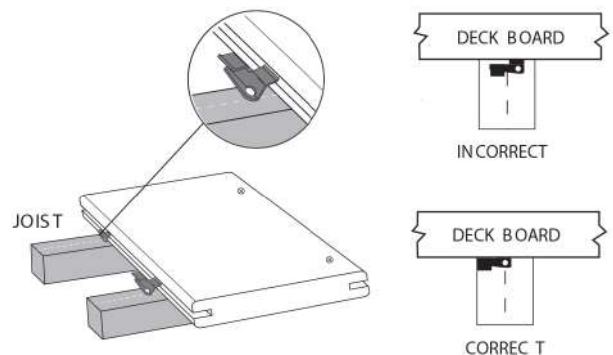



### Step 3: Install First Fastener

While standing on deck board, install provided screw at 45° angle through fastener and into joist, while applying pressure on fastener. Install one fastener and screw at each support joist.

Make sure fastener body is vertical to deck board and the screw is holding fastener down tight to support joist. Adjust torque setting on screw gun to prevent spin out of the screw head.

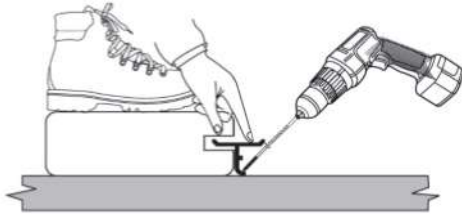

### Step 4: Completing Installation of Boards

Place next deck board into position against fasteners. Slightly raise outer edge of board being installed and slide board onto fasteners until board contacts spacer tabs.

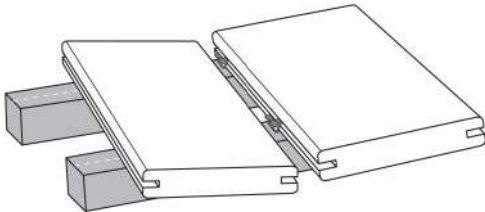

Check gap between boards for consistency. Apply force to ensure board is fully installed.

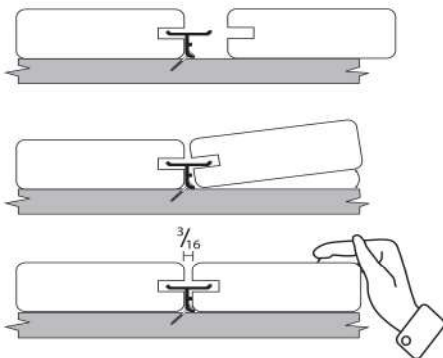

Repeat steps 2 thru 4 until deck is complete.

### HELPFUL TIPS

#### Coverage

- Multiply the number of joists by the number of deck boards to equal the number of fasteners needed.
- 90 fasteners will cover approximately 50 sq.ft. (4.6m<sup>2</sup>) using 5.5" (133mm) decking boards on 16" (410mm) centers.

#### How Do You Attach the Last Board?

To finish, we recommend using Cortex Fasteners for Clubhouse Decking or another brand of quality 2-1/2" (63.5mm) deck screws to secure the last board along its edge. Pre-drill and countersink all deck screws. Use PL Premium Max on rim joist to help secure the board with recommended screws. Pre-drill/screw should be a minimum of 3/4" (25mm) from edge of deck board.

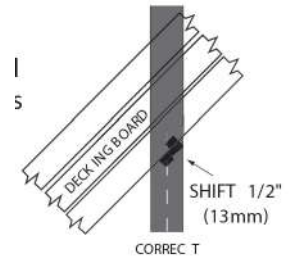

#### 45° angle installation

When deck is in the walled corner of the house, always start with small piece of decking in that corner and work your way out. When installing Connect Clip fasteners, offset the center 1/2" (13mm) toward the long point of joist, so screw will not exit side of joist when driven.

#### How to do a butt seam.

First, install a small framing board 10-12" (250 - 300 mm) alongside the joist on which the seam is going to land. Install additional fastener into previous board above small framing block. Line up your first board in the center of the joist and the small framing board. Install a fastener and screw at each joist of the first board including the joist at the seam. Then install your second board in the same fashion, and place a second fastener at the seam attaching it to the small framing block.

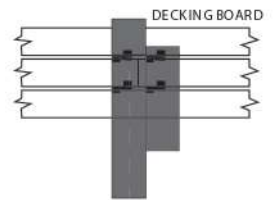

## INSTALLING CONNECT CLIPS WITH TIGER CLAW INSTALLATION GUN

**IMPORTANT:** Read all instructions carefully and completely to ensure proper installation.

**WARNING:** Parts have sharp points and edges. Use extreme caution when handling and installing. Wear safety glasses at all times.

Do not use TigerClaw gun and scrails for marine applications. The individual clips and screws must be used.

### Tools and Materials Needed:

- Tiger Claw Installation Gun
- Safety Glasses
- Compressed Air Supply
- Collated Pneumatic Screws
- TC-G Clip (Horned Tab)
- Rubber Mallet

### Step 1: Insert Pneumatic Screws

Insert a sleeve of collated pneumatic screws into the rear of the magazine.

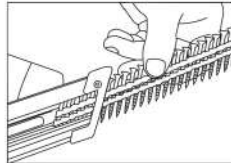

Pull back the spring coil until it locks onto the back of the sleeve.

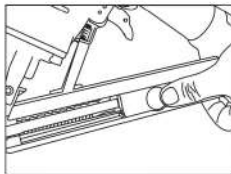

### Step 2: Air/Pressure

Attach air hose. Be sure line pressure is 80-100 psi (pressure adjustment may be needed depending on framing material density).

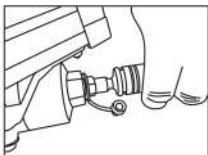

### Step 3: Mount Fastener in Gun

Place fastener into nose of gun with “horned tabs” sticking outwards from gun nose.

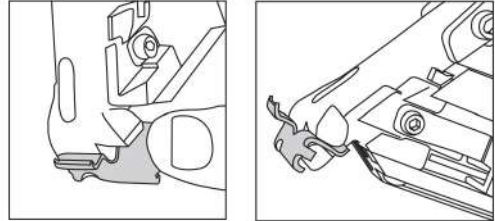

### Step 4: Insert in Groove

Holding the gun upright, insert the horned tab into the groove of the deck board directly over the support joist.

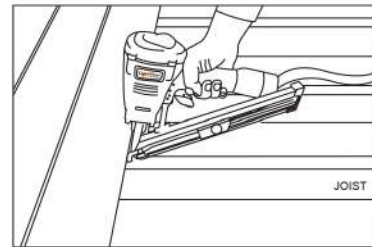

### Step 5: Position/Angle

Once fastener is fully inserted, apply pressure to disengage the safety. Then, lower the back of the gun allowing the magazine to sit on the support joist to assure correct angle, and pull the trigger.



### Step 6: Remove

With the magazine still resting on the joist, slide the nose of the gun to the right removing it from the attached fastener.

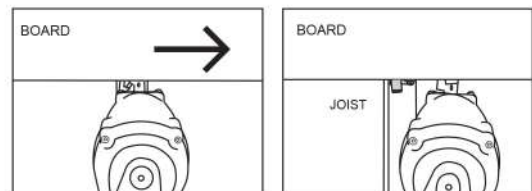

**Repeat until deck is complete.**

## HELPFUL TIPS

- Always keep fingers clear of barrel.
- Never let gun point at body while connected to air supply.
- Do not pull trigger while safety is deactivated.

## How to Replace a Board?

- Make two parallel cuts down the center of the board to be replaced, and remove the center piece.
- Using a small pry bar, remove the remaining pieces of decking from the tabs.
- Using a reciprocating saw, remove the tabs on the side of the board with the screw heads showing.
- Position new board into place, and carefully slide onto remaining tabs.
- Once board is set into position, secure the lead edge with Cortex Fasteners for Clubhouse Decking or another brand of quality 2-1/2" (63.5mm) deck screws.

## Cortex Fastening System

Use the Cortex Hidden Fastening System to hide deck screws on stairs, perimeter boards and more.

## Installation Procedure

### Suggested Drivers:

- Corded drill with 1/2" chuck
  - Cordless drill with 1/2" chuck and 18V battery
  - Impact driver
- 
- Using the Clubhouse setting tool, drive the fastener to the preset level below the deck surface. it must be driven perpendicular to the deck, with two screws per joist.
  - Place the plug into the cored hole and gently tap until it is flush with the deck surface.



## Suggested Fastening Patterns:

- 2 fasteners, 12" or 16" on center for perimeter boards
- 2 fasteners at each stair stringer
- Minimum 3/4" from edge of deck board

## IMPORTANT INFORMATION:

- The Clubhouse setting tool must be used to set the Cortex screw at the correct depth.
- The Clubhouse fastener must be driven perpendicular to the deck surface for proper fit and ideal finished look.
- The cored hole must be free of debris or moisture.
- Use a smooth hammer head to set the Clubhouse plug.
- Use of non-Clubhouse screw or Cortex plug will nullify the warranty of the fastener. (See FastenMaster warranty).
- Fasteners supplied with Cortex plugs are not approved for coastal/marine/water applications. For these applications, stainless fasteners are recommended.

## Clubhouse 'EB-TY' Biscuit Fastening System

- Screw down the outer edge of first deck board using stainless steel screws.
- Place Clubhouse fasteners in deck board slots at each joint.
- Drive the stainless black finish screw at a 45° angle flush to the top of fastener. NOTE: Do not over drive screws.

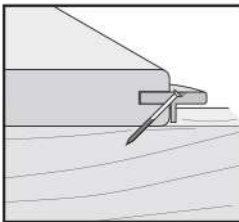

- Slide your next deck board over the exposed Clubhouse fasteners.
- Screw down outer edge of last deck board using stainless steel screws.

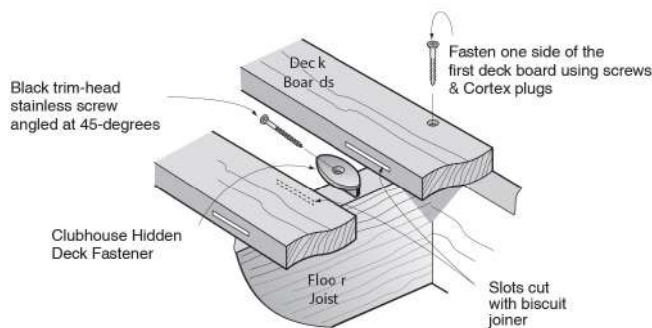

## FAQ/Troubleshooting

### Deck Bounces/Springs when walked on:

- Substructure built more than 16" on center.

*Boards must be secured 16" however for best/sturdier feel use 12" on center with PVC decking.*

- Improper fastening - the deck boards are not fastened properly to the joists.

*Check fastener manufacturer installation guide to ensure fasteners are used correctly. Make sure fasteners are tightly secured.*

### The following conditions may cause the deck to have high and low spots:

- Uneven joists.

*Align joists to get an even substructure.*

- Improper fastening - the deck boards are not fastened properly to the joists.

*Check fastener manufacturer installation guide to ensure fasteners are used correctly. Make sure fasteners are tightly secured.*

- Excessive heat build up - (caused by poor ventilation and/or reflection from windows with Low-E glass) resulting in surface temperature exceeding 160°F

*See ventilation section of installation guide for ventilation guidelines.*

### Deck squeaks when walked on:

- Improper fastening - the deck boards are not fastened properly to the joists.

*Check fastener manufacturer installation guide to ensure fasteners are used correctly. Make sure fasteners are tightly secured.*

- Weak understructure - movement of the joists is making the noise.

*Block joists appropriately to keep movement to a minimum.*

### Excessive expansion / contraction of deck:

- Excessive heat build up - (caused by poor ventilation and/or reflection from windows with Low-E glass) resulting in surface temperature exceeding 160°F

*See ventilation section of installation guide for ventilation guidelines.*

- Improper fastening - the deck boards are not fastened properly to the joists.

*Check fastener manufacturer installation guide to ensure fasteners are used correctly. Make sure fasteners are tightly secured.*

- Substructure installed wet and then dried out and shrunk, causing movement of deck.

*Allow substructure to dry completely then re-secure boards and/or block joist appropriately to make substructure more sturdy.*

#### **Puddles / Standing water on deck:**

- Improper slope/pitch for water run off.

*Deck should slope 1/16" to 1/8" per foot away from the house.*

- Improper fastening - the deck boards are not fastened properly to the joists.

*Check fastener manufacturer installation guide to ensure fasteners are used correctly. Make sure fasteners are tightly secured.*

- Uneven joists.

*Align joists to get an even substructure.*

*Note: Clubhouse PVC Decking will not absorb water. Water will stand until it evaporates or runs off.*

#### **Environmental Blushing:**

- Caused by build up of heat and moisture due to a wide surface area of deck being covered (e.g. by flower pots, rubber backed grill mats).

*Use of rubber backed mats is not recommended on Clubhouse PVC Decking. Raise flower pots with stands/footers to allow airflow under the pot. To remove discoloration caused by blushing apply dry heat source to the area (e.g. with heat gun.) Caution: Do not over heat planks, as this could cause damage.*